



**Technical and Test Institute
for Construction Prague**
Prosecká 811/76a
190 00 Prague
Czech Republic
eota@tzus.cz



Member of



www.eota.eu

European Technical Assessment

**ETA 22/0213
of 03/07/2022**

(English language translation, the original version in Czech language)

Technical Assessment Body issuing the ETA:

Technical and Test Institute for Construction Prague

Trade name of the construction product

G&B Fissaggi Injection System
Extreme Hybrid XTR
Extreme Hybrid XTR Nordic
Extreme Hybrid XTR Summer

Product family to which the construction product belongs

Product area code: 33
Post-installed rebar connections of the sizes Ø8
to Ø25 with injection mortar

Manufacturer

G&B Fissaggi S.r.l.
Corso Savona, 22
Villastellone (TO), 10029
Italy

Manufacturing plant(s)

G&B Fissaggi S.r.l., Plant 4

This European Technical Assessment contains

15 pages including 12 Annexes which form an
integral part of this assessment.

This European Technical Assessment is issued in accordance with regulation (EU) No 305/2011, on the basis of

EAD 330087-01-0601

Translations of this European Technical Assessment in other languages shall fully correspond to the original issued document and should be identified as such.

Communication of this European Technical Assessment, including transmission by electronic means, shall be in full (excepted the confidential Annex(es) referred to above). However, partial reproduction may be made, with the written consent of the issuing Technical Assessment Body - Technical and Test Institute for Construction Prague. Any partial reproduction has to be identified as such.

1. Technical description of the product

The G&B Fissaggi Injection System Extreme Hybrid XTR, Extreme Hybrid XTR Nordic, Extreme Hybrid XTR Summer is used for the connection, by anchoring or overlap joint, of reinforcing bars (rebars) in existing structures made of normal weight concrete. The design of the post-installed rebar connections is done in accordance with the regulations for reinforced concrete constructions.

Reinforcing bars made of steel with a diameter from 8 to 25 mm and G&B Fissaggi Extreme Hybrid XTR, Extreme Hybrid XTR Nordic, Extreme Hybrid XTR Summer chemical mortar are used for rebar connections. The steel element is placed into a drilled hole filled with injection mortar and is anchored via the bond between embedded element, injection mortar and concrete.

The illustration and the description of the product are given in Annex A.

2. Specification of the intended use in accordance with the applicable EAD

The performances given in Section 3 are only valid if the anchor is used in compliance with the specifications and conditions given in Annex B.

The provisions made in this European Technical Assessment are based on an assumed working life of the anchor of 50 years. The indications given on the working life cannot be interpreted as a guarantee given by the producer, but are to be regarded only as a means for choosing the products in relation to the expected economically reasonable working life of the works.

3. Performance of the product and references to the methods used for its assessment

3.1 Mechanical resistance and stability (BWR 1)

Essential characteristic	Performance
Bond strength of post-installed rebar	See Annex C 1
Reduction factor	See Annex C 1
Amplification factor for minimum anchorage length	See Annex C 1

3.2 Safety in case of fire (BWR 2)

Essential characteristic	Performance
Reaction to fire	Class (A1) according to EN 13501-1
Resistance to fire	No performance assessed

3.3 General aspects relating to fitness for use

Durability and serviceability are only ensured if the specifications of intended use according to Annex B 1 are kept.

4. Assessment and verification of constancy of performance (AVCP) system applied with reference to its legal base

According to the Decision 96/582/EC of the European Commission¹ the system of assessment verification of constancy of performance (see Annex V to Regulation (EU) No 305/2011) given in the following table applies.

Product	Intended use	Level or class	System
Metal anchors for use in concrete	For fixing and/or supporting to concrete, structural elements (which contributes to the stability of the construction works) or heavy units	-	1

¹ Official Journal of the European Communities L 254 of 08.10.1996

5. Technical details necessary for the implementation of the AVCP system, as provided in the applicable EAD

The factory production control shall be in accordance with the control plan which is a part of the technical documentation of this European Technical Assessment. The control plan is laid down in the context of the factory production control system operated by the manufacturer and deposited at Technický a zkušební ústav stavební Praha, s.p.² The results of factory production control shall be recorded and evaluated in accordance with the provisions of the control plan.

Issued in Prague on 03.07.2022

By

Ing. Jiří Studnička, Ph.D.
Head of the Technical Assessment Body

² The control plan is a confidential part of the documentation of the European Technical Assessment, but not published together with the ETA and only handed over to the approved body involved in the procedure of AVCP.

Installation post installed rebar

Figure A1: Overlapping joint for rebar connections of slabs and beams

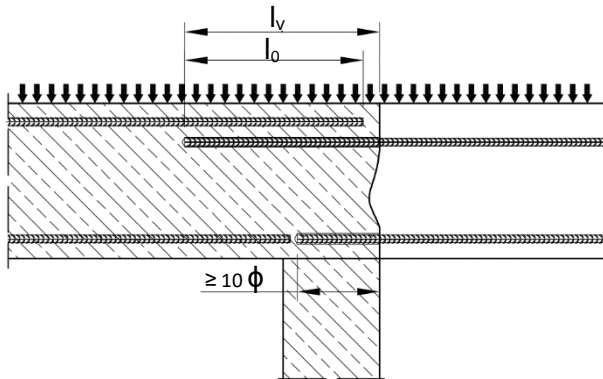

Figure A3: End anchoring of slabs or beams (e.g. designed as simply supported)

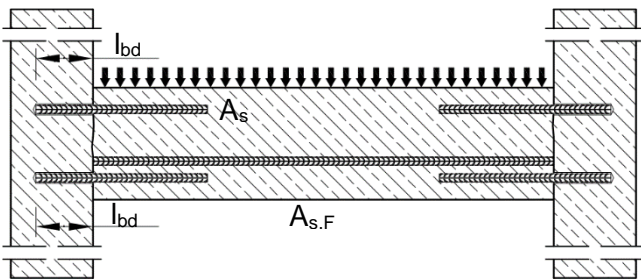

Figure A5: Anchoring of reinforcement to cover the line of acting tensile force

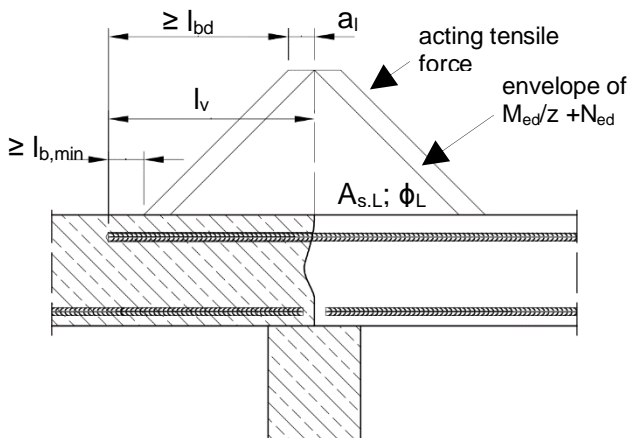

Figure A2: Overlapping joint at a foundation of a wall or column where the rebars are stressed in tension

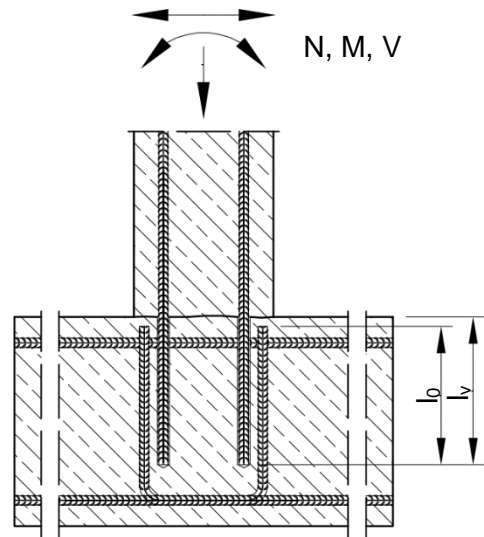
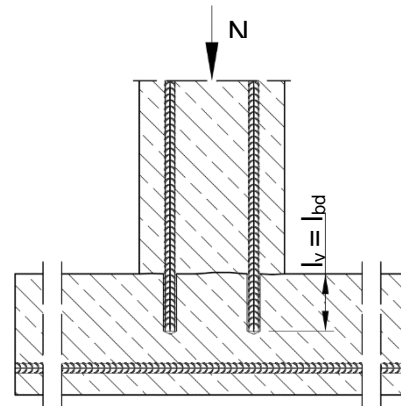

Figure A4: Rebar connection for components stressed primarily in compression. The rebars are stressed in compression.



Note to Figure A1 to A5:

In the Figures no transverse reinforcement is plotted, the transverse reinforcement shall comply with EN 1992-1-1:2004+AC:2010.

Preparing of joints according to Annex B 2

G&B Fissaggi Injection System for rebar connection
Extreme Hybrid XTR, Extreme Hybrid XTR Nordic, Extreme Hybrid XTR Summer

Product description
 Installed condition and examples of use for rebars

Annex A 1

Cartridge system

Coaxial Cartridge:

150 ml, 280 ml, 300 ml up to 333 ml and 380 ml up to 420 ml

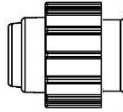

Imprint:

Extreme Hybrid XTR, Nordic, Summer

Processing and safety instructions, shelf life, charge number, manufacturer's information, quantity information

Side-by-Side Cartridge:

235 ml, 345 ml up to 360 ml and 825 ml

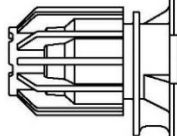

Imprint:

Extreme Hybrid XTR, Nordic, Summer

Processing and safety instructions, shelf life, charge number, manufacturer's information, quantity information

Foil Tube Cartridge:

165 ml and 300 ml

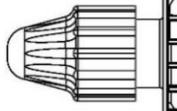

Imprint:

Extreme Hybrid XTR, Nordic, Summer

Processing and safety instructions, shelf life, charge number, manufacturer's information, quantity information

Static mixer M17



Piston plug MP and Mixer extension ML



**G&B Fissaggi Injection System for rebar connection
Extreme Hybrid XTR, Extreme Hybrid XTR Nordic, Extreme Hybrid XTR Summer**

Product description
Injection system

Annex A 2

Reinforcing bar (rebar): $\phi 8$ up to $\phi 25$

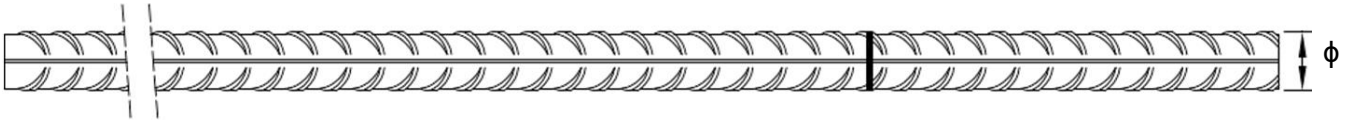

- Minimum value of related rip area $f_{R,min}$ according to EN 1992-1-1:2004+AC:2010
- Rib height of the bar shall be in the range $0,05\phi \leq h_{rib} \leq 0,07\phi$
(ϕ : Nominal diameter of the bar; h_{rib} : Rib height of the bar)

Table A1: Materials Rebar

Designation	Material
Rebar EN 1992-1-1:2004+AC:2010, Annex C	Bars and de-coiled rods class B or C f_{yk} and k according to NDP or NCL of EN 1992-1-1/NA $f_{uk} = f_{tk} = k \cdot f_{yk}$
G&B Fissaggi Injection System for rebar connection Extreme Hybrid XTR, Extreme Hybrid XTR Nordic, Extreme Hybrid XTR Summer	Annex A 3
Product description Specifications Rebar	

Specifications of intended use			
Anchorage subject to:		Working life 50 years	Working life 100 years
HD: Hammer drilling CD: Compressed air drilling	static and quasi-static loads	Ø8 to Ø25	No performance assessed
	seismic action	No performance assessed	No performance assessed
	fire exposure	No performance assessed	No performance assessed
Temperature Range:	- 40°C to +80°C (max long-term temperature +50 °C and max short-term temperature +80 °C)		
<p>Base materials:</p> <ul style="list-style-type: none"> - Reinforced or unreinforced normal weight concrete according to EN 206:2013 + A1:2016. - Strength classes C12/15 to C50/60 according to EN 206:2013 + A1:2016. - Maximum chloride content of 0,40% (CL 0.40) related to the cement content according to EN 206:2013 + A1:2016. - Non-carbonated concrete. <p>Note: In case of a carbonated surface of the existing concrete structure the carbonated layer shall be removed in the area of the post-installed rebar connection with a diameter of $\phi + 60$ mm prior to the installation of the new rebar.</p> <p>The depth of concrete to be removed shall correspond to at least the minimum concrete cover in accordance with EN 1992-1-1:2004+AC:2010. The foregoing may be neglected if building components are new and not carbonated and if building components are in dry conditions.</p> <p>Design:</p> <ul style="list-style-type: none"> - Anchorages are designed under the responsibility of an engineer experienced in anchorages and concrete work. - Verifiable calculation notes and drawings are prepared taking account of the forces to be transmitted. - Design according to EN 1992-1-1:2004+AC:2010, EN 1992-1-2:2004+AC:2008 and Annex B 2. - The actual position of the reinforcement in the existing structure shall be determined on the basis of the construction documentation and taken into account when designing. <p>Installation:</p> <ul style="list-style-type: none"> - Dry or wet concrete. It must not be installed in flooded holes. - Overhead installation allowed. - Hole drilling by hammer drill (HD or compressed air drill mode (CD)). - The installation of post-installed rebar resp. tension anchors shall be done only by suitable trained installer and under supervision on site; the conditions under which an installer may be considered as suitable trained and the conditions for supervision on site are up to the Member States in which the installation is done. - Check the position of the existing rebars (if the position of existing rebars is not known, it shall be determined using a rebar detector suitable for this purpose as well as on the basis of the construction documentation and then marked on the building component for the overlap joint). 			
G&B Fissaggi Injection System for rebar connection Extreme Hybrid XTR, Extreme Hybrid XTR Nordic, Extreme Hybrid XTR Summer			Annex B 1
Intended use Specifications			

Figure B1: General construction rules for post-installed rebars

- Only tension forces in the axis of the rebar may be transmitted
- The transfer of shear forces between new concrete and existing structure shall be designed additionally according to EN 1992-1-1:2004+AC:2010.
- The joints for concreting must be roughened to at least such an extent that aggregate protrude.

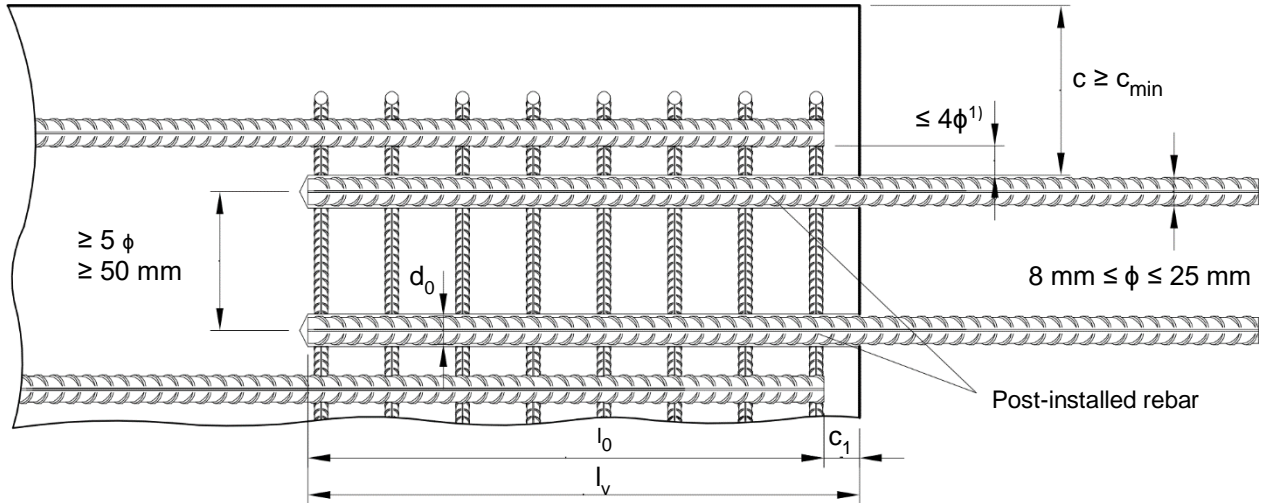

¹⁾ If the clear distance between lapped bars exceeds 4ϕ , then the lap length shall be increased by the difference between the clear bar distance and 4ϕ .

The following applies to Figure B1:

- c concrete cover of post-installed rebar
- c_1 concrete cover at end-face of existing rebar
- c_{min} minimum concrete cover according to Table B1 and to EN 1992-1-1:2004+AC:2010, Section 4.4.1.2
- ϕ diameter of post-installed rebar
- l_0 lap length, according to EN 1992-1-1:2004+AC:2010, Section 8.7.3
- l_v effective embedment depth, $\geq l_0 + c_1$
- d_0 nominal drill bit diameter, see Annex B 4

G&B Fissaggi Injection System for rebar connection
Extreme Hybrid XTR, Extreme Hybrid XTR Nordic, Extreme Hybrid XTR Summer

Intended use
 General construction rules for post-installed rebars

Annex B 2



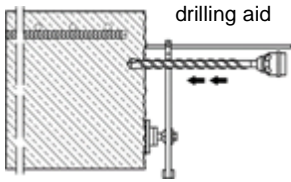





Table B1: Minimum concrete cover min $c^{1)}$ of post-installed rebar and depending of drilling method

Drilling method	Rebar diameter	Without drilling aid	With drilling aid	
HD: Hammer drilling	< 25 mm	$30 \text{ mm} + 0,06 \cdot l_v \geq 2 \phi$	$30 \text{ mm} + 0,02 \cdot l_v \geq 2 \phi$	
	$\geq 25 \text{ mm}$	$40 \text{ mm} + 0,06 \cdot l_v \geq 2 \phi$	$40 \text{ mm} + 0,02 \cdot l_v \geq 2 \phi$	
CD: Compressed air drilling	< 25 mm	$50 \text{ mm} + 0,08 \cdot l_v$	$50 \text{ mm} + 0,02 \cdot l_v$	
	$\geq 25 \text{ mm}$	$60 \text{ mm} + 0,08 \cdot l_v \geq 2 \phi$	$60 \text{ mm} + 0,02 \cdot l_v \geq 2 \phi$	

¹⁾ see Annex B 2, Figure B1

Comments: The minimum concrete cover acc. EN 1992-1-1:2004+AC:2010 must be observed

Table B2: Dispensing tools

Cartridge type/size	Hand tool		Pneumatic tool
Coaxial cartridges 150, 165, 280, 300 up to 333 ml	 e.g. type H297 / H244C		 e.g. type TS 492 X
Coaxial cartridges 380 up to 420 ml	 e.g. type CCM 380/10	 e.g. type H 285 or H244C	 e.g. type TS 485 LX
Side-by-side cartridges 235, 345 up to 360 ml	 e.g. type CBM 330A	 e.g. type H 260	 e.g. type TS 477 LX
Side-by-side cartridges 825 ml	-	-	 e.g. type TS 498X

All cartridges could also be extruded by a battery tool.

**G&B Fissaggi Injection System for rebar connection
Extreme Hybrid XTR, Extreme Hybrid XTR Nordic, Extreme Hybrid XTR Summer**

Intended use
Minimum concrete cover
Dispensing tools

Annex B 3

Table B3: Brushes, piston plugs, max anchorage depth and mixer extension, hammer (HD) and compressed air (CD) drilling

Bar size ϕ	Drill bit - ϕ		d_b Brush - ϕ		$d_{b,min}$ min. Brush - ϕ	Piston plug	Cartridge: All sizes				Cartridge: 825 ml	
	HD	CD					Hand or battery tool		Pneumatic tool		Pneumatic tool	
							$l_{v,max}$	Mixer extension	$l_{v,max}$	Mixer extension	$l_{v,max}$	Mixer extension
[mm]	[mm]		[mm]	[mm]		[mm]		[mm]		[mm]		
8	12	-	SC12	14	12,5	-	700	ML10/0,75	1000	ML10/0,75	1000	ML10/0,75
10	14	-	SC14	16	14,5	MP14						
12	16		SC16	18	16,5	MP16						
14	18		SC18	20	18,5	MP18						
16	20		SC20	22	20,5	MP20						
20	25	-	SC25	27	25,5	MP25	500	ML10/0,75	700	ML10/0,75	1000	ML10/0,75
	-	26	SC26	28	26,5	MP25						
25	32		SC32	34	32,5	MP32						

Cleaning and installation tools

Hand pump

(Volume 750 ml, $h_0 \geq 10 d_s$, $d_0 \leq 20\text{mm}$)



Manual slide valve

(min 6 bar)



Brush SC



Piston Plug MP

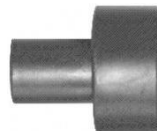

Brush extension SL



G&B Fissaggi Injection System for rebar connection
Extreme Hybrid XTR, Extreme Hybrid XTR Nordic, Extreme Hybrid XTR Summer

Intended use
 Cleaning and installation tools

Annex B 4

Table B4: Working and curing time Extreme Hybrid XTR		
Temperature in base material	Maximum working time	Minimum curing time
T	t_{work}	t_{cure}
- 5 °C to - 1 °C	90 min	6 h
+ 0 °C to + 4 °C	45 min	3 h
+ 5 °C to + 9 °C	25 min	2 h
+ 10 °C to + 14 °C	20 min	100 min
+ 15 °C to + 19 °C	15 min	80 min
+ 20 °C to + 29 °C	6 min	45 min
+ 30 °C to + 34 °C	4 min	25 min
+ 35 °C to + 39 °C	2 min	20 min
Cartridge temperature	+5 °C up to +40 °C	
Table B5: Working and curing time Extreme Hybrid XTR Nordic		
Temperature in base material	Maximum working time	Minimum curing time
T	t_{work}	t_{cure}
- 10 °C to - 6 °C	60 min	4 h
- 5 °C to - 1 °C	45 min	2 h
+ 0 °C to + 4 °C	25 min	80 min
+ 5 °C to + 9 °C	10 min	45 min
+ 10 °C to + 14 °C	4 min	25 min
+ 15 °C to + 19 °C	3 min	20 min
+ 20 °C to + 29 °C	2 min	15 min
Cartridge temperature	0 °C up to +30 °C	
Table B6: Working and curing time Extreme Hybrid XTR Summer		
Temperature in base material	Maximum working time	Minimum curing time
T	t_{work}	t_{cure}
+ 10 °C to + 14 °C	30 min	5 h
+ 15 °C to + 19 °C	20 min	210 min
+ 20 °C to + 29 °C	15 min	145 min
+ 30 °C to + 34 °C	10 min	80 min
+ 35 °C to + 39 °C	6 min	45 min
+ 40 °C to + 44 °C	4 min	25 min
+45 °C	2 min	20 min
Cartridge temperature	+5 °C up to +45 °C	
G&B Fissaggi Injection System for rebar connection Extreme Hybrid XTR, Extreme Hybrid XTR Nordic, Extreme Hybrid XTR Summer		Annex B 5
Intended use Working and curing time		

Installation instructions

Drilling of the bore hole

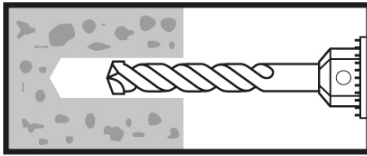

Attention: Before drilling, remove carbonated concrete and clean contact areas (see Annex B 1). Aborted drill holes shall be filled with mortar.

1. Hammer drilling (HD) / Compressed air drilling (CD)

Drill a hole to the required embedment depth.
Drill bit diameter according to Table B3.
Proceed with Step 2 (MAC or CAC).

Manual Air Cleaning (MAC)

for drill hole diameter $d_0 \leq 20\text{mm}$ and drill hole depth $h_0 \leq 10\phi$ with drilling method HD/CD

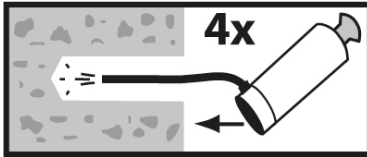

Attention! Standing water in the bore hole must be removed before cleaning.

2a. Blow the bore hole clean minimum 4x from the bottom or back by hand pump (Annex B 4).

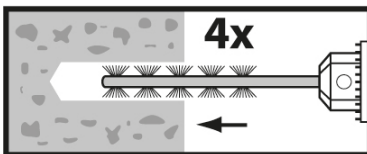

2b. Attach brush SC according to Table B3 to a drilling machine or a cordless screwdriver. Brush the bore hole minimum 4x over the entire embedment depth in a twisting motion (if necessary, use a brush extension SL).

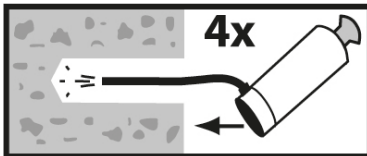

2c. Finally blow the bore hole clean minimum 4x from the bottom or back by hand pump (Annex B 4).

Compressed Air Cleaning (CAC):

All diameter with drilling method HD/CD

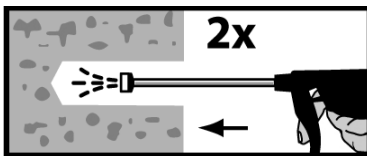

Attention! Standing water in the bore hole must be removed before cleaning.

2a. Blow the bore hole clean minimum 2x with compressed air (min. 6 bar) (Annex B 4) over the entire embedment depth until return air stream is free of noticeable dust. (If necessary, an extension shall be used.)

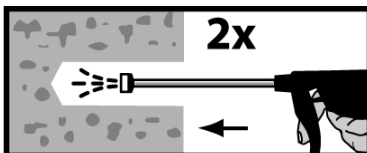

2b. Attach brush SC according to Table B3 to a drilling machine or a cordless screwdriver. Brush the bore hole minimum 2x over the entire embedment depth in a twisting motion. (If necessary, a brush extension SL shall be used.)

**G&B Fissaggi Injection System for rebar connection
Extreme Hybrid XTR, Extreme Hybrid XTR Nordic, Extreme Hybrid XTR Summer**

Intended use
Installation instructions

Annex B 6

Installation instructions (continuation)

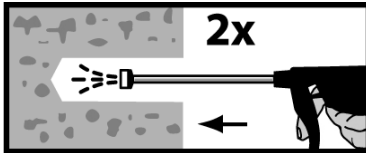

2c. Finally blow the bore hole clean minimum 2x with compressed air (min. 6 bar) (Annex B 4) over the entire embedment depth until return air stream is free of noticeable dust. (If necessary, an extension shall be used.)

Protect cleaned bore hole against re-contamination in an appropriate way. If necessary, repeat cleaning process directly before dispensing the mortar. In-flowing water must not contaminate the bore hole again

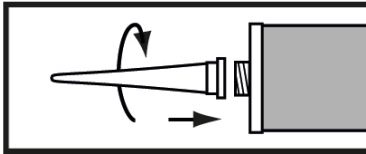

3. Screw on static-mixing nozzle M17 and load the cartridge into an appropriate dispensing tool.
If necessary, cut off the foil tube clip before use.
For every working interruption longer than the maximum working time t_{work} (Annex B 5) as well as for new cartridges, a new static-mixer shall be used.

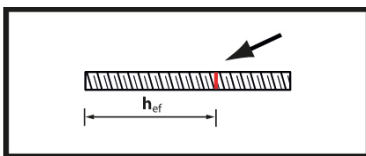

4. Mark embedment depth on the reinforcing bar .
The reinforcing bar shall be free of dirt, grease, oil or other foreign material.

5. Mark mixer nozzle and extension with mortar level mark l_m and anchorage depth l_v resp. $l_{e,ges}$
Quick estimation: $l_m = 1/3 \cdot l_v$
Optimum mortar volume:

$$l_m = l_v \text{ resp. } l_{e,ges} \cdot \left(1,2 \cdot \frac{\phi^2}{d_0^2} - 0,2 \right)$$

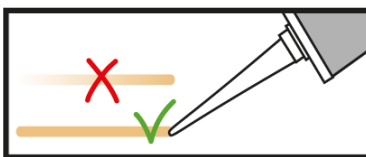
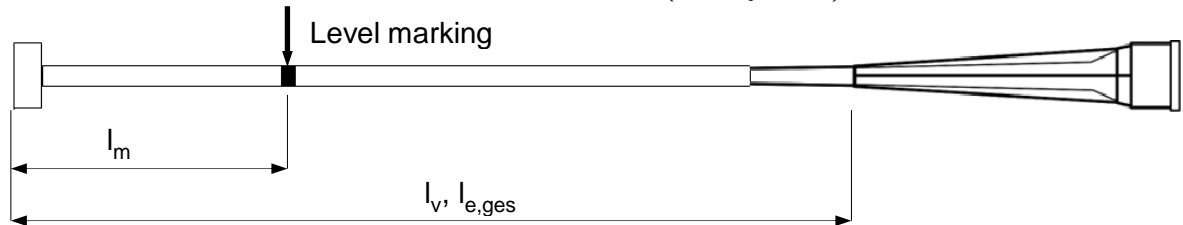

6. Not proper mixed mortar is not sufficient for fastening.
Dispense and discard mortar until an uniform grey colour is shown (at least 3 full strokes; for foil tube cartridges at least 6 full strokes).

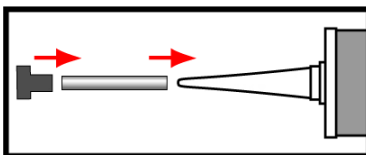

7. Piston plugs MP and mixer nozzle extensions ML shall be used according to Table B3.
Assemble mixing nozzle, mixer extension and piston plug before injecting mortar.

G&B Fissaggi Injection System for rebar connection
Extreme Hybrid XTR, Extreme Hybrid XTR Nordic, Extreme Hybrid XTR Summer

Intended use
Installation instructions (continuation)

Annex B 7

Installation instructions (continuation)

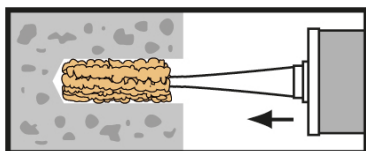

8a. Injecting mortar without piston plug MP:
 Starting at bottom of the hole and fill the hole with adhesive until the mortar level mark l_m is visible. (If necessary, a mixer nozzle extension shall be used.)
 Slowly withdraw of the static mixing nozzle avoid creating air pockets
 Observe the temperature related working time t_{work} (Annex B 5).

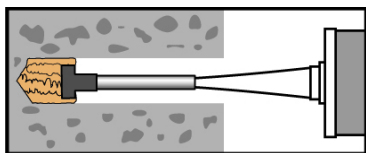

8b. Injecting mortar with piston plug MP:
 Insert piston plug to bottom of the hole and fill the hole with mortar until mortar level mark l_m is visible. (If necessary, a mixer nozzle extension shall be used.)
 During injection the piston plug is pushed out of the bore hole by the back pressure of the mortar.
 Observe the temperature related working time t_{work} (Annex B 5).

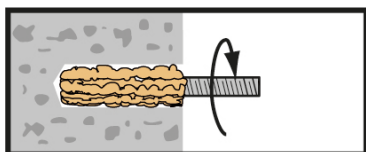

9. Insert the reinforcing bar while turning slightly up to the embedment mark.

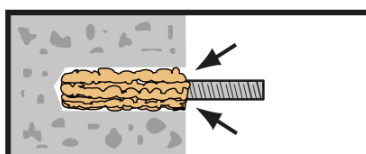

10. Annular gap between reinforcing bar and base material must be completely filled with mortar. Otherwise, the installation must be repeated starting from step 7 before the maximum working time t_{work} has expired.

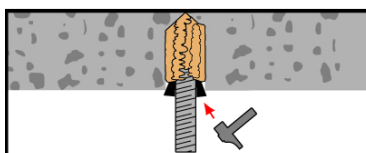

11. For application in vertical upwards direction the reinforcing bar shall be fixed (e.g. wedges).



12. Temperature related curing time t_{cure} (Annex B 5) must be observed.
 The full load to the reinforcing bar may be applied after the full curing time t_{cure} has elapsed.

**G&B Fissaggi Injection System for rebar connection
 Extreme Hybrid XTR, Extreme Hybrid XTR Nordic, Extreme Hybrid XTR Summer**

Intended use
 Installation instructions (continuation)

Annex B 8

Minimum anchorage length and minimum lap length

The minimum anchorage length $l_{b,min}$ and the minimum lap length $l_{0,min}$ according to EN 1992-1-1:2004+AC:2010 ($l_{b,min}$ acc. to Eq. 8.6 and Eq. 8.7 and $l_{0,min}$ acc. to Eq. 8.11) shall be multiply by the amplification factor α_{lb} according to Table C1.

Table C1: Amplification factor α_{lb} related to concrete class and drilling method

Concrete class	Drilling method	Bar size	Amplification factor α_{lb}
C12/15 to C50/60	All drilling method	8 mm to 25 mm	1,5

Table C2: Reduction factor k_b for all drilling methods

Rebar	Concrete class								
	C12/15	C16/20	C20/25	C25/30	C30/37	C35/45	C40/50	C45/55	C50/60
ϕ									
8 mm to 20 mm	1,0								
25 mm	1,0								0,93

Table C3: Design values of the ultimate bond strength $f_{bd,PIR}$ in N/mm² for all drilling methods and for good conditions

$$f_{bd,PIR} = k_b \cdot f_{bd}$$

with

f_{bd} : Design value of the ultimate bond stress in N/mm² considering the concrete classes, the rebar diameter, the drilling method for good bond condition (for all other bond conditions multiply the values by $\eta_1 = 0.7$) and recommended partial factor $\gamma_C = 1,5$ according to

EN 1992-1-1:2004+AC:2010.

k_b : Reduction factor according to Table C2

Rebar	Concrete class								
	C12/15	C16/20	C20/25	C25/30	C30/37	C35/45	C40/50	C45/55	C50/60
ϕ									
8 mm to 20 mm	1,6	2,0	2,3	2,7	3,0	3,4	3,7	4,0	4,3
25 mm	1,6	2,0	2,3	2,7	3,0	3,4	3,7	4,0	4,0

G&B Fissaggi Injection System for rebar connection
Extreme Hybrid XTR, Extreme Hybrid XTR Nordic, Extreme Hybrid XTR Summer

Performance

Minimum anchorage length and minimum lap length, Amplification factor, Reduction factor and Design values of ultimate bond resistance

Annex C 1